

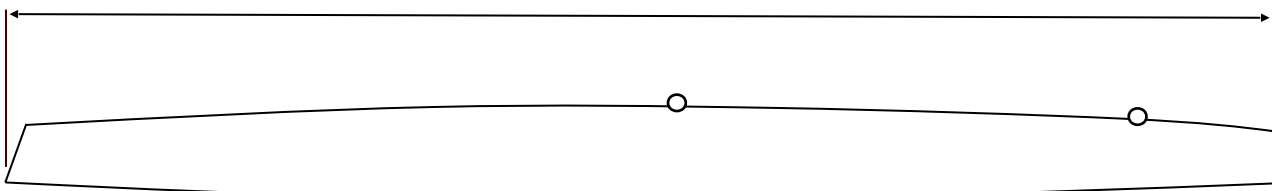

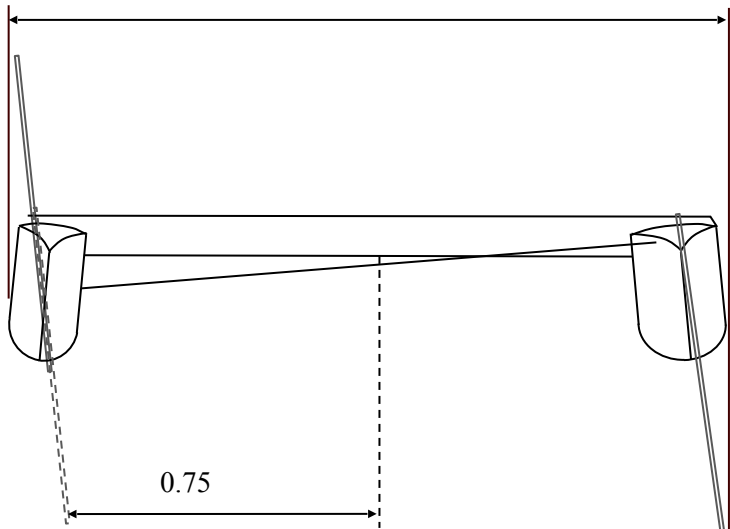

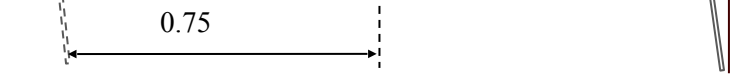
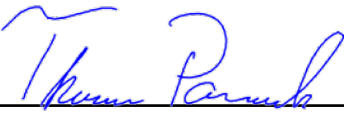

# International A-Catamaran Measurement Certificate

## Hull Measurement Form

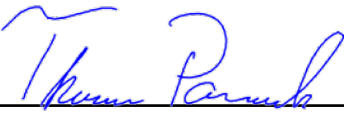
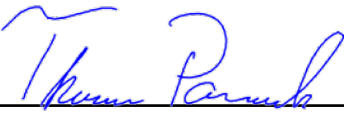
 <p style="text-align: center;">5.49</p>	<table border="1" style="width: 100%; border-collapse: collapse;"> <tr> <th colspan="2" style="background-color: #e0e0e0;">Overall Length</th> </tr> <tr> <td style="width: 70%;">Max</td> <td style="text-align: right;">5,49</td> </tr> <tr> <td>Actual</td> <td style="text-align: right;">5,482</td> </tr> </table>	Overall Length		Max	5,49	Actual	5,482				
Overall Length											
Max	5,49										
Actual	5,482										
 <p style="text-align: center;">2.30</p>	<table border="1" style="width: 100%; border-collapse: collapse;"> <tr> <th colspan="2" style="background-color: #e0e0e0;">Overall Beam including all appendages</th> </tr> <tr> <td style="width: 70%;">Max</td> <td style="text-align: right;">2,3</td> </tr> <tr> <td>Actual</td> <td style="text-align: right;">2,287</td> </tr> </table>	Overall Beam including all appendages		Max	2,3	Actual	2,287				
Overall Beam including all appendages											
Max	2,3										
Actual	2,287										
 <p style="text-align: center;">0.75</p>	<table border="1" style="width: 100%; border-collapse: collapse;"> <tr> <th colspan="2" style="background-color: #e0e0e0;">Minimum distance to centerline of all appendages in any position</th> </tr> <tr> <td style="width: 70%;">Min</td> <td style="text-align: right;">0,75</td> </tr> <tr> <td>Actual</td> <td style="text-align: right;">0,763</td> </tr> </table>	Minimum distance to centerline of all appendages in any position		Min	0,75	Actual	0,763				
Minimum distance to centerline of all appendages in any position											
Min	0,75										
Actual	0,763										
<table border="1" style="width: 100%; border-collapse: collapse;"> <tr> <th style="width: 50%; background-color: #e0e0e0;">Hull Identification</th> <th style="width: 50%; background-color: #e0e0e0;">Comments</th> </tr> <tr> <td>Hull No.</td> <td rowspan="4" style="vertical-align: top;">Originally measured 8/5/2016, appendages remeasured due to update.</td> </tr> <tr> <td>ISAF Plaque No.</td> <td style="text-align: center;">640</td> </tr> <tr> <td>Builder</td> <td style="text-align: center;">Exploder</td> </tr> <tr> <td>Material</td> <td style="text-align: center;">Carbon</td> </tr> </table>		Hull Identification	Comments	Hull No.	Originally measured 8/5/2016, appendages remeasured due to update.	ISAF Plaque No.	640	Builder	Exploder	Material	Carbon
Hull Identification	Comments										
Hull No.	Originally measured 8/5/2016, appendages remeasured due to update.										
ISAF Plaque No.		640									
Builder		Exploder									
Material		Carbon									
<p><i>All measurements are in meters and to three decimal places.</i></p>											
<table border="1" style="width: 100%; border-collapse: collapse;"> <tr> <td style="width: 60%; vertical-align: top;"> <p><b>Measurers Declaration:</b> I declare that I have measured hull and appendages and they comply with all class rules.</p> <p><b>Date of Measurement:</b> <u>22/4/2018</u></p> <p><b>Measurer's Name:</b> <u>Thomas Paasch</u></p> <p><b>Appointed by:</b> <u>Danish Sailing Association</u></p> <p><b>Measurer's Signature:</b> <u></u></p> </td> <td style="width: 40%; text-align: center; vertical-align: middle;">  <p>Measurer's Stamp</p> </td> </tr> </table>		<p><b>Measurers Declaration:</b> I declare that I have measured hull and appendages and they comply with all class rules.</p> <p><b>Date of Measurement:</b> <u>22/4/2018</u></p> <p><b>Measurer's Name:</b> <u>Thomas Paasch</u></p> <p><b>Appointed by:</b> <u>Danish Sailing Association</u></p> <p><b>Measurer's Signature:</b> <u></u></p>	 <p>Measurer's Stamp</p>								
<p><b>Measurers Declaration:</b> I declare that I have measured hull and appendages and they comply with all class rules.</p> <p><b>Date of Measurement:</b> <u>22/4/2018</u></p> <p><b>Measurer's Name:</b> <u>Thomas Paasch</u></p> <p><b>Appointed by:</b> <u>Danish Sailing Association</u></p> <p><b>Measurer's Signature:</b> <u></u></p>	 <p>Measurer's Stamp</p>										
<p>* Refer current measurers guidelines when completing form.</p>											