

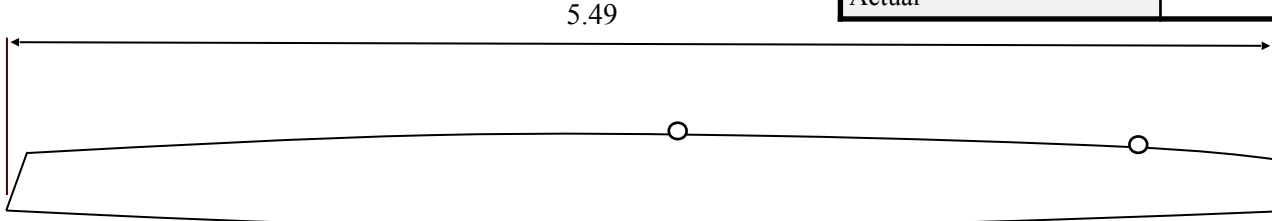

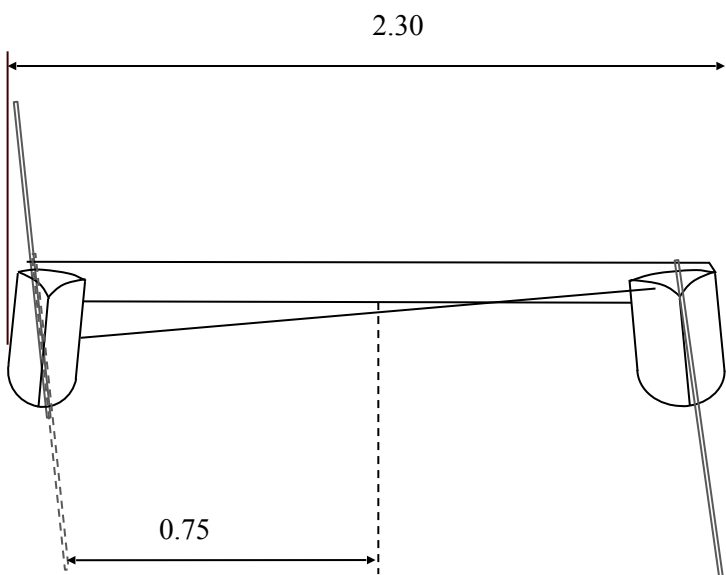

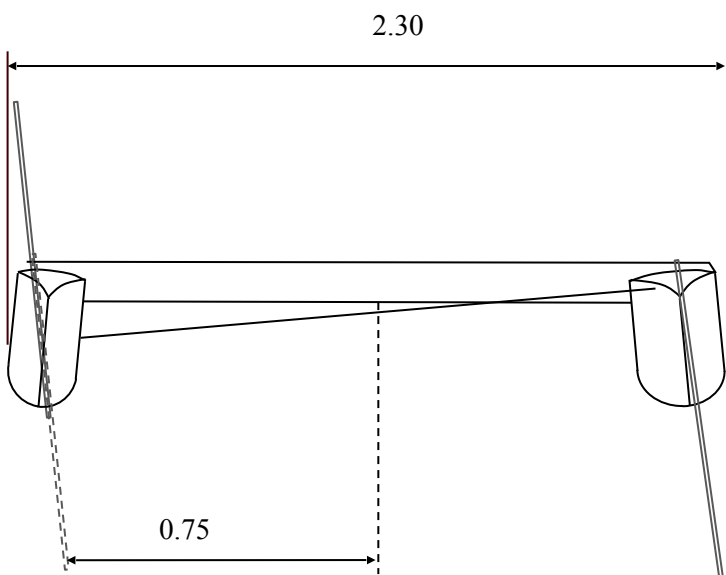

International A-Catamaran Measurement Certificate

Hull Measurement Form

|  <p style="text-align: center;">5.49</p> | <table border="1" style="width: 100%; border-collapse: collapse;"> <tr> <th colspan="2" style="background-color: #cccccc;">Overall Length</th> </tr> <tr> <td style="width: 70%;">Max</td> <td style="text-align: right;">5,49</td> </tr> <tr> <td>Actual</td> <td style="text-align: right;">5,484</td> </tr> </table> | Overall Length | | Max | 5,49 | Actual | 5,484 | | | | | |
|---|---|---|--|---|-----------------------------|-----------------|-------------------------|---------------|----------------------|----------------------------|------------------------------|--|
| Overall Length | | | | | | | | | | | | |
| Max | 5,49 | | | | | | | | | | | |
| Actual | 5,484 | | | | | | | | | | | |
|  <p style="text-align: center;">2.30</p> | <table border="1" style="width: 100%; border-collapse: collapse;"> <tr> <th colspan="2" style="background-color: #cccccc;">Overall Beam including all appendages</th> </tr> <tr> <td style="width: 70%;">Max</td> <td style="text-align: right;">2,3</td> </tr> <tr> <td>Actual</td> <td style="text-align: right;">2,295</td> </tr> </table> | Overall Beam including all appendages | | Max | 2,3 | Actual | 2,295 | | | | | |
| Overall Beam including all appendages | | | | | | | | | | | | |
| Max | 2,3 | | | | | | | | | | | |
| Actual | 2,295 | | | | | | | | | | | |
|  <p style="text-align: center;">0.75</p> | <table border="1" style="width: 100%; border-collapse: collapse;"> <tr> <th colspan="2" style="background-color: #cccccc;">Minimum distance to centerline of all appendages in any position</th> </tr> <tr> <td style="width: 70%;">Min</td> <td style="text-align: right;">0,75</td> </tr> <tr> <td>Actual</td> <td style="text-align: right;">0,765</td> </tr> </table> | Minimum distance to centerline of all appendages in any position | | Min | 0,75 | Actual | 0,765 | | | | | |
| Minimum distance to centerline of all appendages in any position | | | | | | | | | | | | |
| Min | 0,75 | | | | | | | | | | | |
| Actual | 0,765 | | | | | | | | | | | |
| <table border="1" style="width: 100%; border-collapse: collapse;"> <tr> <th style="width: 50%; background-color: #cccccc;">Hull Identification</th> <th style="width: 50%;">Comments</th> </tr> <tr> <td>Hull No.</td> <td></td> </tr> <tr> <td>ISAF Plaque No.</td> <td style="text-align: center;">552</td> </tr> <tr> <td>Builder</td> <td>Exploder</td> </tr> <tr> <td>Material</td> <td>Carbon</td> </tr> </table> | | Hull Identification | Comments | Hull No. | | ISAF Plaque No. | 552 | Builder | Exploder | Material | Carbon | |
| Hull Identification | Comments | | | | | | | | | | | |
| Hull No. | | | | | | | | | | | | |
| ISAF Plaque No. | 552 | | | | | | | | | | | |
| Builder | Exploder | | | | | | | | | | | |
| Material | Carbon | | | | | | | | | | | |
| <p><i>All measurements are in meters and to three decimal places.</i></p> | | | | | | | | | | | | |
| <table style="width: 100%;"> <tr> <td style="width: 30%;">Measurers Declaration:</td> <td style="width: 40%;">I declare that I have measured hull and appendages and they comply with all class rules.</td> <td rowspan="5" style="width: 30%; text-align: center; vertical-align: middle;">  Measurer's Stamp </td> </tr> <tr> <td>Date of Measurement:</td> <td style="text-align: center;">28/12/2015</td> </tr> <tr> <td>Measurer's Name:</td> <td style="text-align: center;">Thomas Paasch</td> </tr> <tr> <td>Appointed by:</td> <td style="text-align: center;">Danish Sailing Association</td> </tr> <tr> <td>Measurer's Signature:</td> <td style="text-align: center;"></td> </tr> </table> | | Measurers Declaration: | I declare that I have measured hull and appendages and they comply with all class rules. |  Measurer's Stamp | Date of Measurement: | 28/12/2015 | Measurer's Name: | Thomas Paasch | Appointed by: | Danish Sailing Association | Measurer's Signature: |  |
| Measurers Declaration: | I declare that I have measured hull and appendages and they comply with all class rules. |  Measurer's Stamp | | | | | | | | | | |
| Date of Measurement: | 28/12/2015 | | | | | | | | | | | |
| Measurer's Name: | Thomas Paasch | | | | | | | | | | | |
| Appointed by: | Danish Sailing Association | | | | | | | | | | | |
| Measurer's Signature: |  | | | | | | | | | | | |
| <p>* Refer current measurers guidelines when completing form.</p> | | | | | | | | | | | | |

| | | | | |
|--|--|--|--|--|
| | | | | |
| | | | | |
| | | | | |
| | | | | |
| | | | | |
| | | | | |
| | | | | |
| | | | | |
| | | | | |
| | | | | |

| | | | | |
|--|--|--|--|--|
| | | | | |
| | | | | |
| | | | | |
| | | | | |
| | | | | |
| | | | | |
| | | | | |
| | | | | |
| | | | | |
| | | | | |