

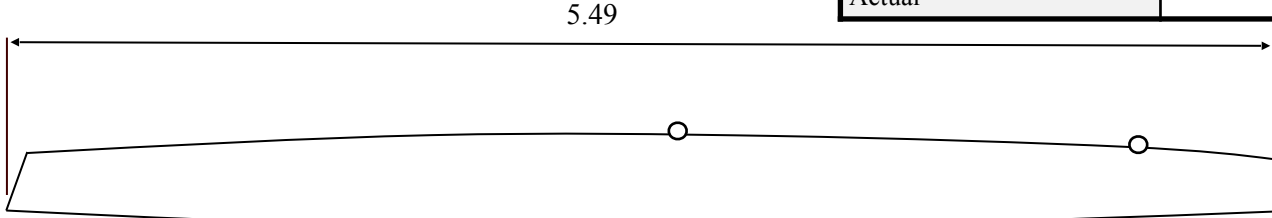

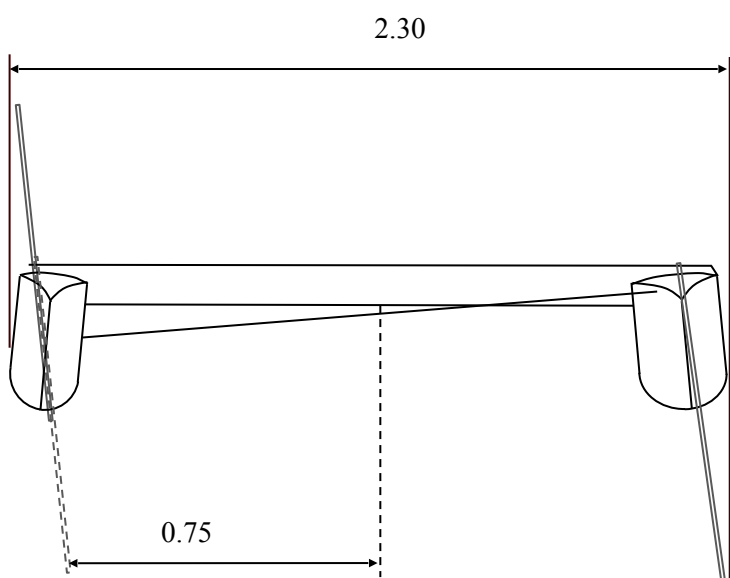

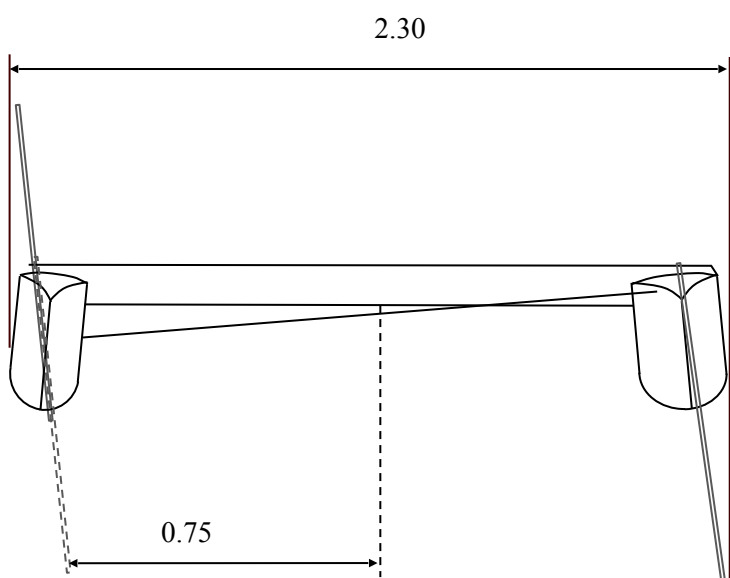

# International A-Catamaran Measurement Certificate

## Hull Measurement Form

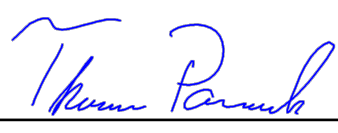
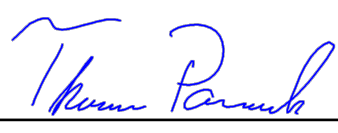
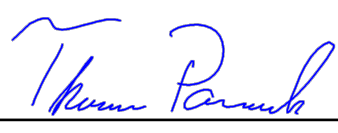
 <p style="text-align: center;">5.49</p>	<table border="1" style="width: 100%; border-collapse: collapse;"> <tr> <th colspan="2" style="background-color: #cccccc;">Overall Length</th> </tr> <tr> <td style="width: 70%;">Max</td> <td style="text-align: right;">5,49</td> </tr> <tr> <td>Actual</td> <td style="text-align: right;">5,490</td> </tr> </table>	Overall Length		Max	5,49	Actual	5,490					
Overall Length												
Max	5,49											
Actual	5,490											
 <p style="text-align: center;">2.30</p>	<table border="1" style="width: 100%; border-collapse: collapse;"> <tr> <th colspan="2" style="background-color: #cccccc;">Overall Beam including all appendages</th> </tr> <tr> <td style="width: 70%;">Max</td> <td style="text-align: right;">2,3</td> </tr> <tr> <td>Actual</td> <td style="text-align: right;">2,300</td> </tr> </table>	Overall Beam including all appendages		Max	2,3	Actual	2,300					
Overall Beam including all appendages												
Max	2,3											
Actual	2,300											
 <p style="text-align: center;">0.75</p>	<table border="1" style="width: 100%; border-collapse: collapse;"> <tr> <th colspan="2" style="background-color: #cccccc;">Minimum distance to centerline of all appendages in any position</th> </tr> <tr> <td style="width: 70%;">Min</td> <td style="text-align: right;">0,75</td> </tr> <tr> <td>Actual</td> <td style="text-align: right;">0,758</td> </tr> </table>	Minimum distance to centerline of all appendages in any position		Min	0,75	Actual	0,758					
Minimum distance to centerline of all appendages in any position												
Min	0,75											
Actual	0,758											
<table border="1" style="width: 100%; border-collapse: collapse;"> <tr> <th style="width: 50%; background-color: #cccccc;">Hull Identification</th> <th style="width: 50%; background-color: #cccccc;">Comments</th> </tr> <tr> <td>Hull No.</td> <td rowspan="4" style="vertical-align: top;">World Sailing sticker has been replaced after paint job 11/8-2019</td> </tr> <tr> <td>ISAF Plaque No.</td> <td style="text-align: center;">929</td> </tr> <tr> <td>Builder</td> <td>Holland Composites</td> </tr> <tr> <td>Material</td> <td>Carbon</td> </tr> </table>		Hull Identification	Comments	Hull No.	World Sailing sticker has been replaced after paint job 11/8-2019	ISAF Plaque No.	929	Builder	Holland Composites	Material	Carbon	
Hull Identification	Comments											
Hull No.	World Sailing sticker has been replaced after paint job 11/8-2019											
ISAF Plaque No.		929										
Builder		Holland Composites										
Material		Carbon										
<p><i>All measurements are in meters and to three decimal places.</i></p> <table border="1" style="width: 100%; border-collapse: collapse;"> <tr> <td style="width: 30%;"><b>Measurers Declaration:</b></td> <td style="width: 40%;">I declare that I have measured hull and appendages and they comply with all class rules.</td> <td rowspan="5" style="width: 30%; text-align: center; vertical-align: middle;">  <p>Measurer's Stamp</p> </td> </tr> <tr> <td><b>Date of Measurement:</b></td> <td><u>1/7/2017</u></td> </tr> <tr> <td><b>Measurer's Name:</b></td> <td><u>Thomas Paasch</u></td> </tr> <tr> <td><b>Appointed by:</b></td> <td><u>Danish Sailing Association</u></td> </tr> <tr> <td><b>Measurer's Signature:</b></td> <td></td> </tr> </table>		<b>Measurers Declaration:</b>	I declare that I have measured hull and appendages and they comply with all class rules.	 <p>Measurer's Stamp</p>	<b>Date of Measurement:</b>	<u>1/7/2017</u>	<b>Measurer's Name:</b>	<u>Thomas Paasch</u>	<b>Appointed by:</b>	<u>Danish Sailing Association</u>	<b>Measurer's Signature:</b>	
<b>Measurers Declaration:</b>	I declare that I have measured hull and appendages and they comply with all class rules.	 <p>Measurer's Stamp</p>										
<b>Date of Measurement:</b>	<u>1/7/2017</u>											
<b>Measurer's Name:</b>	<u>Thomas Paasch</u>											
<b>Appointed by:</b>	<u>Danish Sailing Association</u>											
<b>Measurer's Signature:</b>												
<p>* Refer current measurers guidelines when completing form.</p>												